

# TP 19 / TP 37

Rubber Track Platforms





## TP 19 / TP 37 Rubber Track Platforms



The TP-19 and TP-37 rubber track carrier platforms can be used for several purposes, including drill rig conversions, and pipe, water tank and drilling tooling transport. This rubber track carriage is the platform of choice for compaction grouting and foundation repair contractors, drilling and general contractors, landscape designers and farmers.

The TP-19 and TP-37 carriers are mounted on durable rubber tracks with auto-brake, and can be ordered with an optional remote control drive, four leveling outriggers and an auxiliary power connection to run your hydraulic tooling.

- 19 or 37 HP gasoline engine
- Built-in hydraulic power unit
- 6.5 gallon fuel tank
- Optional four outriggers
- Optional auxiliary hydraulic power
- Optional remote control driving
- Optional Diesel engine upgrade
- Optional larger tracks for 8,000 lb capacity
- Rubber Tracks with autobrake

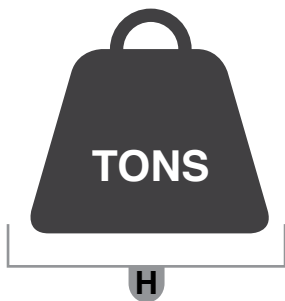
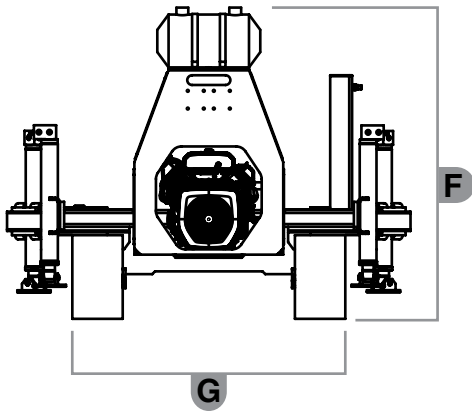
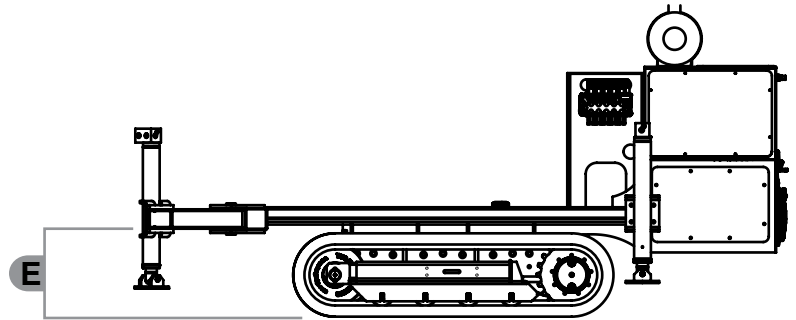
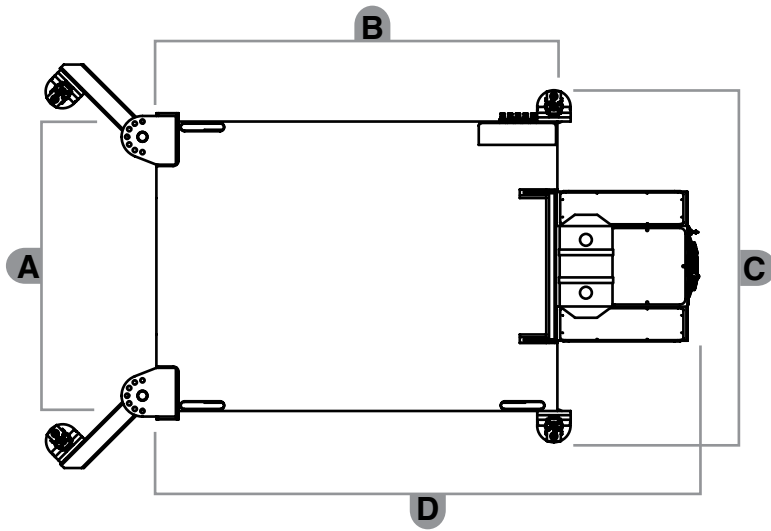

## DIMENSIONS

- A. Flatbed width**  
52" - 132 cm.
- B. Flatbed length**  
72" - 182 cm.
- C. Total platform width**  
60.25" - 153 cm.
- D. Total platform length**  
97.87" - 248 cm.
- E. Platform height**  
16.78" - 42 cm.
- F. Total height**  
55.93" - 142 cm.
- G. Track width**  
49" - 124 cm.
- H. Weight (approximate)**  
680 kg - 1,500 lbs.

## Engine

- 19 hp (14 kW), Honda gasoline engine, or 37hp (27.6kW) Kohler gasoline engine (Diesel engine optional)
- Air cooled
- 12 V electric start
- RPM and hour meter gauge

## Hydraulic System

- 8 gpm (30 lpm) max combined hydraulic flow
- Max 3000 psi (206 bar)
- Two stage gear pump
- Pressure guage

## Track System

- Stationary track system (230 mm (9 in) wide )
- NACHI 2B track motor with automatic brake system
- Built-in grease filled tensioning arm and spring

## Options

- 4 x leveling outriggers
- 3B tracks with 8,000 lb capacity
- Auxiliary power connection for hydraulic power tools
- Wireless remote control drive
- Diesel Engine upgrade





TP 19 / TP 37  
Rubber Track Platforms





---

**Address:** 5517 W. Sligh Ave, Suite 100. Tampa, FL 33634  
**Phone number:** (813) 464-2299  
**Toll-Free number:** 1-888-508-**RIGS** (7447)  
**E-mail:** [info@tmgmfg.com](mailto:info@tmgmfg.com)  
**Website:** [www.tmgmfg.com](http://www.tmgmfg.com)

**Facebook:** [f TMGManufacturing](#)  
**Youtube:** [v TMGManufacturing](#)  
**Instagram:** [@ TMGManufacturing](#)  
**Linkedin:** [in TMG-Manufacturing](#)

---